

Prentice

Safety Equipment

Model ... **Mr Mezzanine**

Part # 49019

FUNCTION A switch gate system for high level guard railing

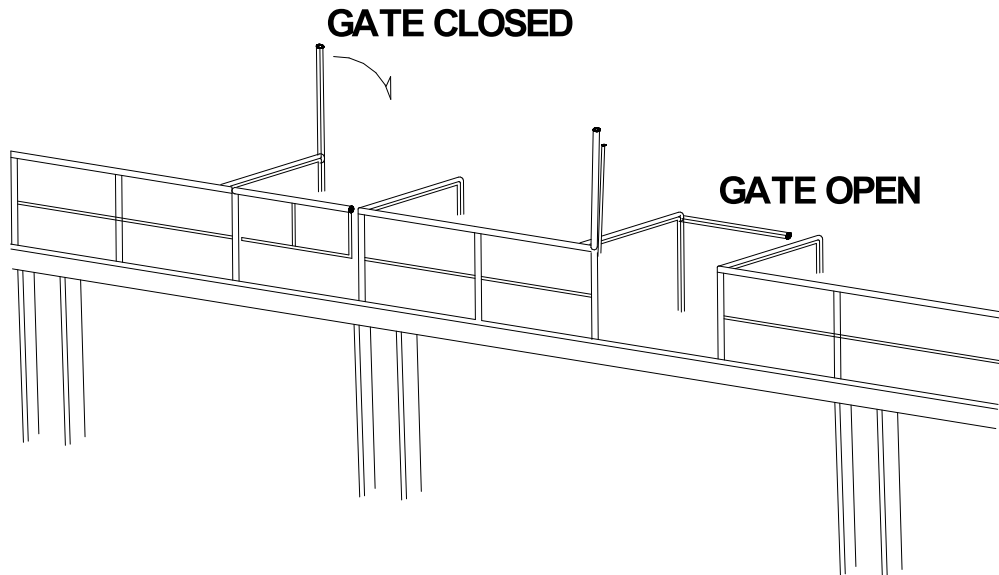

Features

- Supplied in kit form for easy installation
- Extremely small footprint
- Requires no lubrication
- Optional multiple pallet facility
- Safety trim clearly indicates status
- Galvanised Option
- Weld or bolt to floor
- Maximise natural Light
- Minimise visual clutter
- Instils sense of security
- Fail safe operation
- Low maintenance cost

METHODS REPLACED

- Flip over canopies
- Sliding gates
- Ropes and chains
- Drop bars

OPTIONS

- Kick Panel
- Side Access

Prentice Industries Pty Limited

Design and Manufacture of Materials Handling Equipment

Sydney Australia

Ph 1300 551 383 Fax 1300 796 441 email sales@prentice.com.au

Prentice

Safety Equipment

Model ... **Mr Mezzanine**

Part # 49019

PRENTICE INDUSTRIES
Sydney.... www.prentice.com.au
Mr Mezzanine #49019

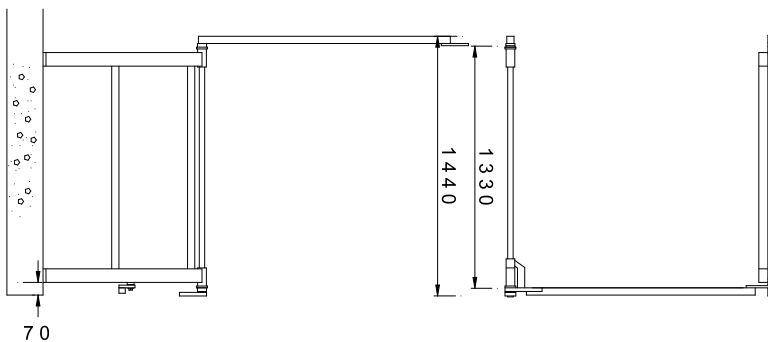
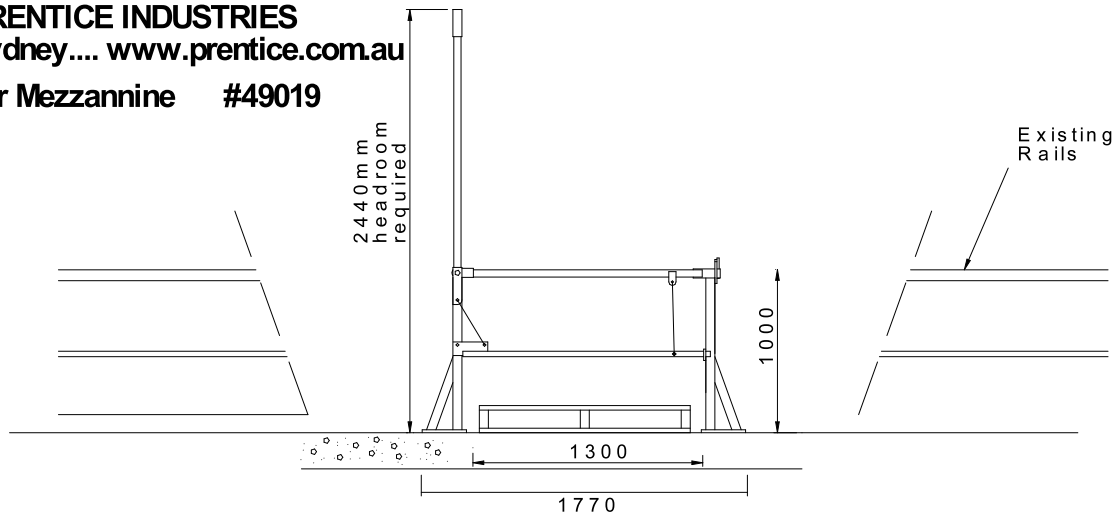

To see this as an animation - go to.... www.prentice.com.au
product index, mezzanine

Prentice Industries Pty Limited

Design and Manufacture of Materials Handling Equipment

Sydney Australia

Ph 1300 551 383 Fax 1300 796 441 email sales@prentice.com.au

Prentice

Safety Equipment

Model ... **Mr Mezzanine**

Part # 49019

#49045 Mr mezz - Doublegate

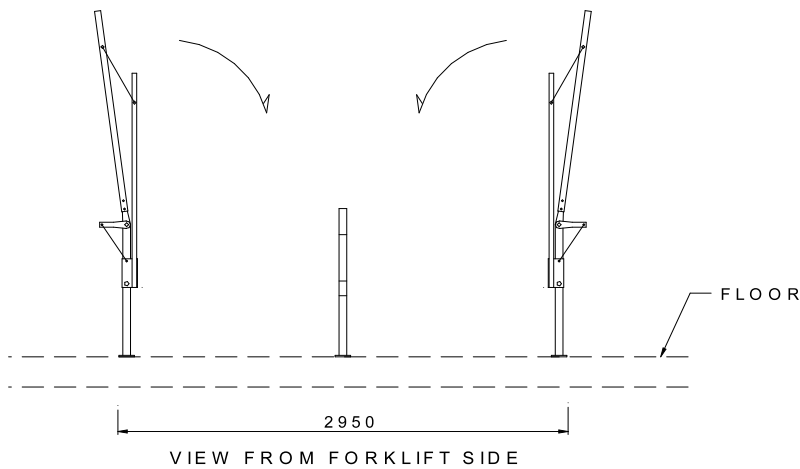
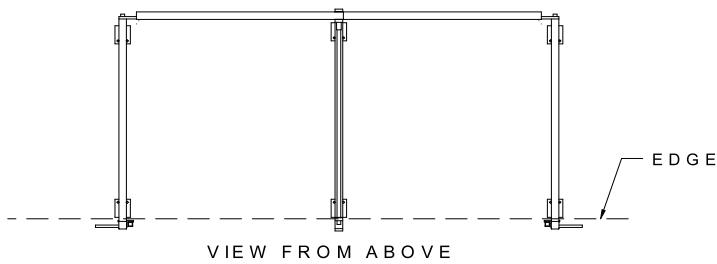

Prentice Industries Pty Limited

Design and Manufacture of Materials Handling Equipment

Sydney Australia

Ph 1300 551 383 Fax 1300 796 441 email sales@prentice.com.au

Prentice

Safety Equipment

Model ... **Mr Mezzanine** Part # 49019

Ordering Information....

Designate someone to check with operations that the standard model will fill their needs. It may be that the loads being positioned are bigger than a standard pallet. Check headroom clearance is ok. Remember - extra width = extra headroom. Check right or left hand arrangement [Standard right hand operation is shown above]

Model # for standard Mr Mezzanine Item 49019

Options...

Option Kickplate at void side	# 49020
Option Side Access to pallet	# 49021
Option galvanised Finish	# 49023
Option extra width	# 49024 [maximum 2100mm]
Option extra depth	# 49026
Option 304 stainless steel	# 49022
Mr Mezz Turntable Size	# 49025
Mr Mezz 90 Degree	# 49050
[in from north, out from east]	
Mr mezz - Doublegate	# 49045

Shipping details for #49019 ...

The kit is flat packed on a skid - 140 x 120 x 35 Cm weight 100Kg.

Visit Our pages at www.prentice.com.au for other innovative products

Prentice Industries Pty Limited

Design and Manufacture of Materials Handling Equipment

Sydney Australia

Ph 1300 551 383 Fax 1300 796 441 email sales@prentice.com.au

Prentice

Safety Equipment

Model ... **Mr Mezzanine** Part # 49019

Special Note

This product conforms with the Australian BAS.
The top railing height is set at 1000mm.

Should you have headroom issues, we can reduce the top rail height to 900mm, which will still conform with AS1657, the standard relating to platforms and handrails.

Prentice Industries Pty Limited

Design and Manufacture of Materials Handling Equipment

Sydney Australia

Ph 1300 551 383 Fax 1300 796 441 email sales@prentice.com.au

Mr.Mezzanine - #49019

Operating Instructions

The mezzanine safety gate has had simplicity designed into it. It has been designed to conform with AS1657, the standard relating to platforms and handrails, so you can feel secure working in the gate area.

When the single arm is up, it grants you access to the pallet.

To open the forklift side of the gate system,

- Slide the locking bar towards you until it stops.
- Reach up and grasp the single arm
- Slowly pull down

To close the forklift side of the gate system,

- Grasp the single arm
- Slowly lift up
- Slide the locking bar away from you until it stops.

The system is counterbalanced, so the effort is low. This imparts some momentum to it's operation....

- **Operate slowly**
- **Keep hold of the bar until movement is complete**
- **Never stand underneath the bar when operating the gate**
- **Never climb under the single bar**
- **Never try to lift the bar with your forklift**